

# Lake System Health

A. D. Latornell Conference Symposium  
November 17, 2011

# Agenda

- ▶ Purpose of the Model
- ▶ Lake Classification
- ▶ Land Use Policy
- ▶ Over Threshold Lakes
- ▶ Model limitations



# Use of the Model

**MNR/MOE**



**Municipalities**



# Function of the Model



- ▶ One tool to plan for growth on our lakes
- ▶ Classify lakes based on ‘Sensitivity’ to phosphorus
  - Responsiveness
  - Mobility
- ▶ Basis for land use policies

# What the Model Doesn't Do

- ▶ Stop development
  - OMB decisions
- ▶ Stop removal of shoreline vegetation
- ▶ Protect Wetlands
- ▶ Require new development to be set back from the shoreline

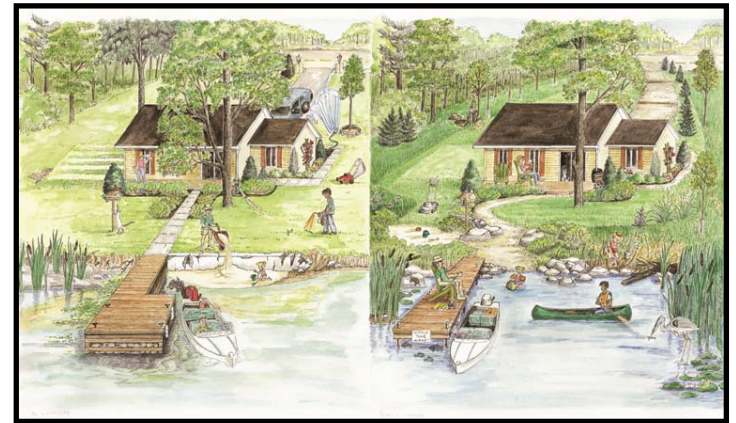

# What the Model does Do

- ▶ Indicates the level of sensitivity of a lake to development
- ▶ Indicates when a lake has more phosphorus than is healthy
- ▶ Guides development policy
- ▶ Be the basis for a stewardship program



# Lake Classification

How Sensitive is a Lake to Development?

		Mobility	
		High	Low
Responsiveness	High	High Sensitivity	Moderate Sensitivity
	Low	Moderate Sensitivity	Low Sensitivity

# Lake Classification

- ▶ Three Classes of Lakes
  - High Sensitivity
  - Moderate Sensitivity
  - Low Sensitivity
- ▶ Over Threshold

		Mobility	
		High	Low
Responsiveness	High	High Sensitivity	Moderate Sensitivity
	Low	Moderate Sensitivity	Low Sensitivity

# Over Threshold Lake

Clear (Torrance) Lake  
Long Term Monitoring Data

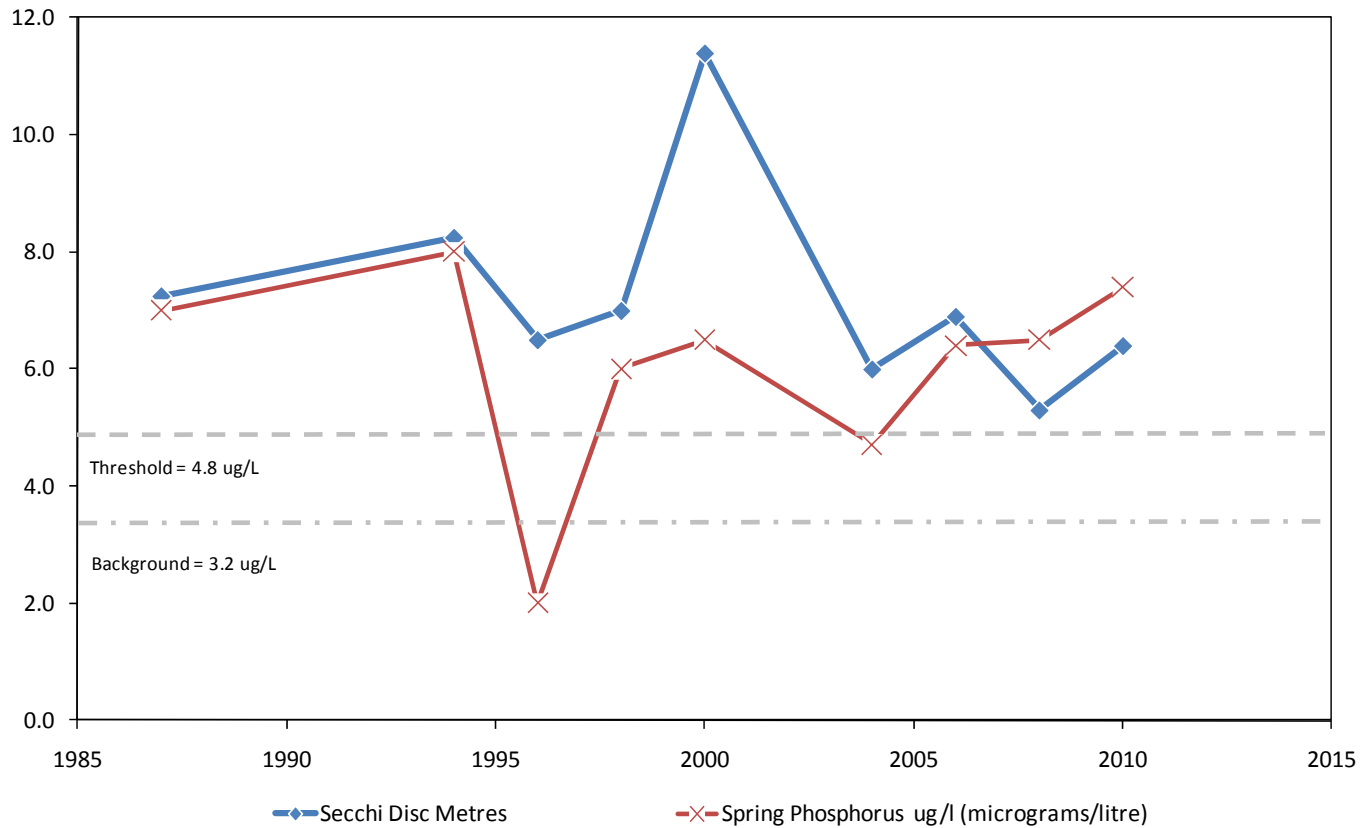

# Land Use Policy



- ▶ Purpose – To provide clear policy direction for environmentally sound development around our lakes and rivers
- ▶ Objectives –
  - Reduce the impact of existing development, and
  - Minimize the impact of new development on lake health

# Land Use Policy

- ▶ Policy should address all development situations, including:
  - lot creation,
  - development of existing vacant lots,
  - redevelopment of lots, and
  - all land use designations (waterfront, community, urban centres and major highway inputs)

# General Policy

- ▶ Target of 75% of linear shoreline frontage in natural state
- ▶ 30 m setback for leaching beds
- ▶ 20 m setback for all structures

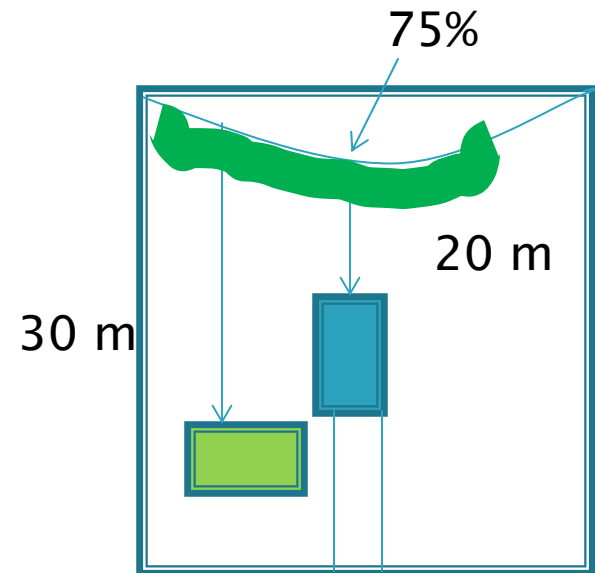



# Low Sensitivity Lakes

- ▶ Other policies more restrictive
- ▶ Encouraged to use site plan or development permit for substantial building and commercial, industrial and institutional development.

		Mobility	
		High	Low
Responsiveness	High	High Sensitivity	Moderate Sensitivity
	Low	Moderate Sensitivity	Low Sensitivity

# Moderate Sensitivity

Activity	Lot Creation	Vacant Land	Redevelopment
Municipal Services			
WQIA #1			
WQIA #2			
Site Plan			
Septic (binds Tp)			
Tp Mitigation Pl.			
Monitoring			
Net Reduct. Tp			

		Mobility	
		High	Low
Resposiven	High	High Sensitivity	Moderate Sensitivity
	Low	Moderate Sensitivity	Low Sensitivity

# Site Plan Agreement

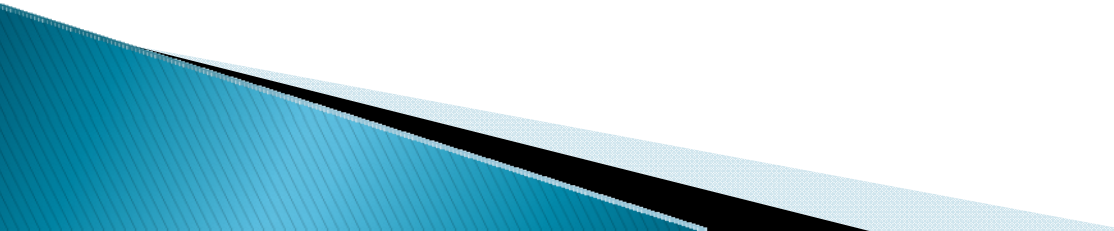
- Location of structures
  - Retention of shoreline vegetation
  - Maintain native cover
  - Location of driveways, pathways, roads
  - Stormwater management and construction mitigation
- 

# High Sensitivity

Activity	Lot Creation	Vacant Land	Redevelopment
Municipal Services			
WQIA #1	✔	✔	
WQIA #2	✔		
Site Plan	✔	✔	✔
Septic (binds Tp)	✔	✔	✔
Tp Mitigation Pl.	✔	✔	✔
Monitoring			
Net Reduct. Tp			✔

		Mobility	
		High	Low
Responsive	High	High Sensitivity	Moderate Sensitivity
	Low	Moderate Sensitivity	Low Sensitivity

# Phase 1 WQ Impact Assessment

- ▶ To determine IF development can proceed
  - Site analysis
  - Surrounding area analysis
  - Soil characteristics
  - Vegetation cover
  - Water flow

# Phase 2 WQ Assessment

- ▶ To determine **HOW** development should occur
  - Recommend building and septic sites
  - Stormwater and Construction Mitigation Plan
  - Shoreline buffer, protection of native vegetation
  - Monitoring plan

# Over Threshold

Activity	Lot Creation	Vacant Land	Redevelopment
Municipal Services	✓		
WQIA #1	✓	✓	
WQIA #2	✓	✓	
Site Plan	✓	✓	✓
Septic (binds Tp)	✓	✓	✓
Tp Mitigation Pl.	✓	✓	✓
Monitoring	✓	✓	
Net Reduct. Tp	✓		✓

		Mobility	
		High	Low
Responsive	High	High Sensitivity	Moderate Sensitivity
	Low	Moderate Sensitivity	Low Sensitivity

# Over Threshold

Activity	Lot Creation	Vacant Land	Redevelopment
OPA	✔		
ZBL	✔	✔	
Tree Cutting By-law	✔		
Site Alteration By-law	✔		

		Mobility	
		High	Low
Responsive	High	High Sensitivity	Moderate Sensitivity
	Low	Moderate Sensitivity	Low Sensitivity

# Over Threshold

- ▶ Remedial Action Program, in conjunction with Lake Association, may provide specific policy
  - Removing municipal sewage outflow
  - Stewardship
  - Septic reinspection process
- ▶ Limits to Growth Assessment
  - Based on existing policy

# Operational Issues

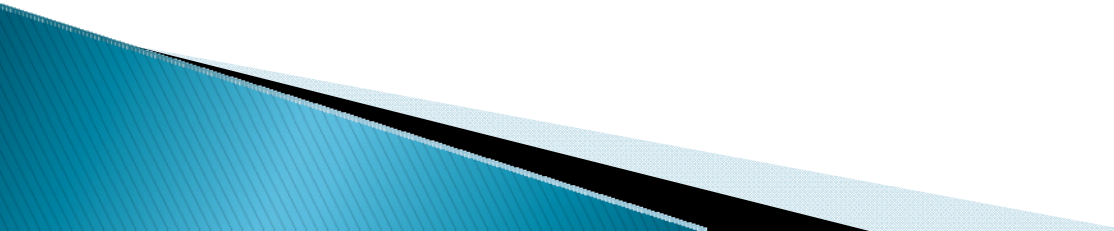
- ▶ Dystrophic/High DOC lakes (coloured)
  - ▶ Measured but not modeled values over threshold
  - ▶ Shallow/Unstratified lakes
  - ▶ Shallow lakes that go anoxic
  - ▶ Lakes with very low TP
  - ▶ Regular updates are required
- 

# Thank You

